

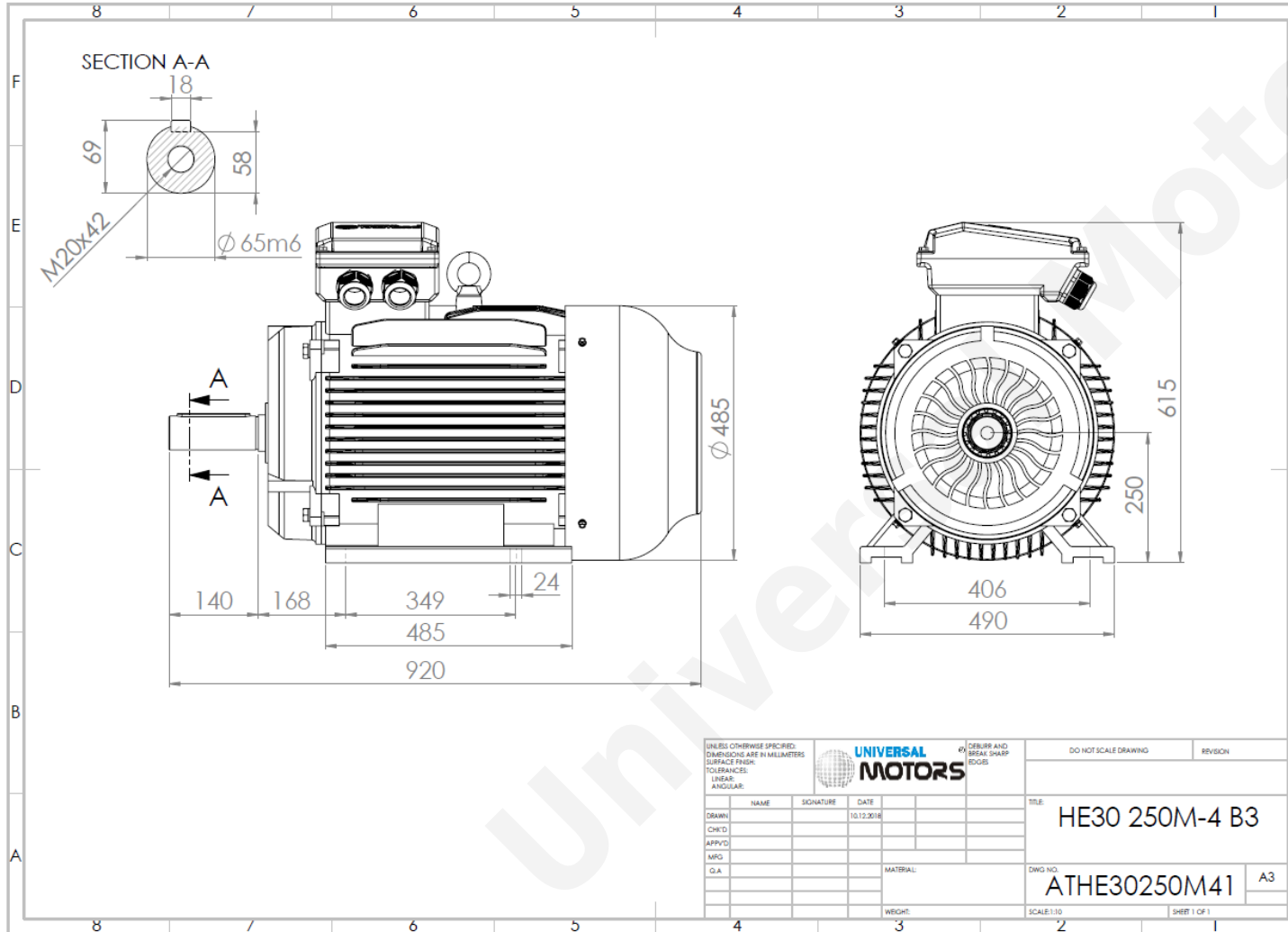

# TECHNICAL DATA

Three Phase Electric Motors - Cast Iron Frame  
 HE30 250 M-6 IE2  
 37 kW / 50 Cv  
 980 RPM



Motor type:	<b>HE30 250 M-6 IE2</b>
Output:	<b>37 kW / 50 Cv</b>
Speed (min <sup>-1</sup> ):	<b>980 RPM</b>
Frequency:	<b>50 Hz</b>
Voltage:	<b>400 V</b>
Current:	<b>69 A</b>
Power factor (Cos Ø):	<b>0.84</b>
Poles:	<b>6</b>
Insulation class:	<b>F</b>
Temperature rise Class:	<b>B</b>
Efficiency 50%:	<b>91.9 %</b>
Efficiency 75%:	<b>92.6 %</b>
Efficiency 100%:	<b>92.2 %</b>
Torque:	<b>361 N.m</b>
Tstarting/Tnominal:	<b>2.1</b>
Istarting/Inominal:	<b>7.1</b>
Tmaximum/Tnominal:	<b>2.1</b>
Noise:	<b>67 Db(A)</b>
Weight:	<b>405 Kg</b>
Bearing DE:	<b>6314 C3</b>
Bearing NDE:	<b>6314 C3</b>

Regime - S1

Altitude - 1000m

Environment Temperature - 40°C

## CONTACTS:

UNIVERSAL MOTORS Tel: +351 252 299 080  
 Rua de São Brás,745 Fax: +351 252 299 089  
 4480-782 VILA DO CONDE Mail: [geral@universalmotors.pt](mailto:geral@universalmotors.pt)

\* References applied only in the UK